

**SPECIFICATION
FOR
LCM Module**

MODULE No:	KD101WSFPD036
CUSTOMER:	

STARTEK	INITIAL	DATE
PREPARED BY		
CHECKED BY		
APPROVED BY		

CUSTOMER	INITIAL	DATE
APPROVED BY		

Contents

1. Block Diagram	5
2. Outline dimension	6
3. Input terminal Pin Assignment	7
4. LCD Optical Characteristics	9
4.1 Optical specification.....	9
5. Electrical Characteristics	12
5.1 Absolute Maximum Rating.....	12
5.2 DC Electrical Characteristics.....	12
5.3 LED Backlight Characteristics.....	13
6. AC Characteristic	15
6.1 Input Clock and Data Timing.....	15
6.2 Input Timing.....	16
6.3 DE Mode.....	16
6.4 SYNC Mode.....	17
6.5 Data Input Format.....	18
7. LCD Module Out-Going Quality Level	19
7.1 VISUAL & FUNCTION INSPECTION STANDARD	19
7.1.1 Inspection conditions.....	19
7.1.2 Definition.....	19
7.1.3 Sampling Plan.....	20
7.1.4 Criteria (Visual).....	21
8. Reliability Test Result	25
9. Cautions and Handling Precautions	26
9.1 Handling and Operating the Module.....	26
9.2 Storage and Transportation.....	26
10. Packing	27

Part. No	KD101WSFPD036	REV	V1.1	Page 3 of 27
	常备库存 Stock For Sale	长期供货 Long Time supply	支持小量 NO MOQ	品种齐全 In Full Range

*** Description**

This is a color active matrix TFT (Thin Film Transistor) LCD (liquid crystal display) that uses amorphous silicon TFT as a switching device. This module is composed of a Transmissive type TFT-LCD Panel, driver circuit, back-light unit. The resolution of a 10.1" TFT-LCD contains 1024x600 pixels, and can display up to 16.7M colors.

*** TFT Features**

General Information Items	Specification	Unit	Note
	Main Panel		
Display area(AA)	222.72(H)*125.28(V) (10.1inch)	mm	-
Driver element	TFT active matrix	-	-
Display colors	16.7M	colors	-
Number of pixels	1024(RGB)*600	dots	-
Pixel arrangement	RGB vertical stripe	-	-
Pixel pitch	0.2175(H) × 0.2088(V)	mm	-
Viewing angle	ALL	o'clock	-
Controller IC	EK73215& EK79001	-	-
LCM Interface	24 BIT RGB	-	-
Display mode	Transmissive/ Normally Black	-	-
Operating temperature	-20~+70	°C	-
Storage temperature	-30~+80	°C	-

*** Mechanical Information**

Item		Min.	Typ.	Max.	Unit	Note
Module size	Horizontal(H)		235.1		mm	-
	Vertical(V)		143.2		mm	-
	Depth(D)		2.8		mm	-
Weight			189		g	-

1. Block Diagram

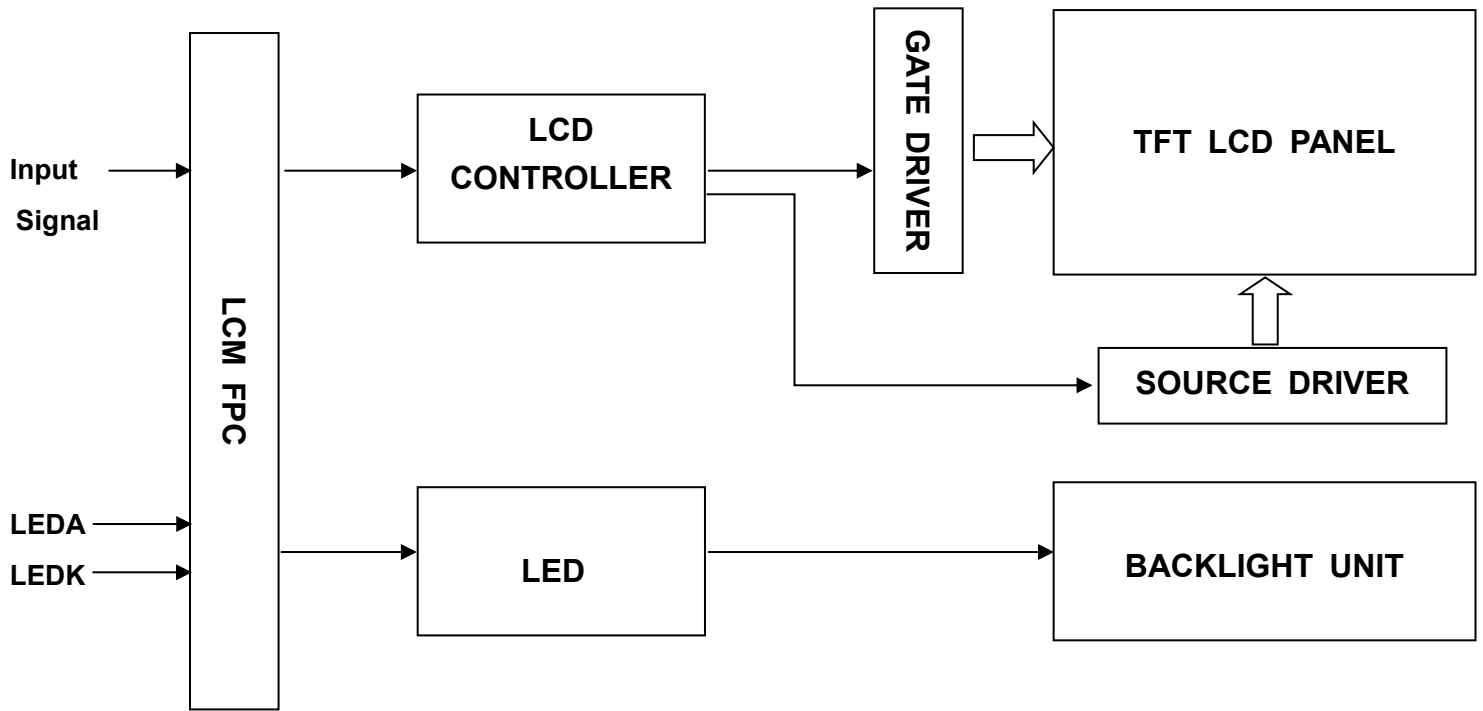

Part. No	KD101WSFPD036	REV	V1.1	Page 5 of 27
常备库存 Stock For Sale	长期供货 Long Time supply	支持小量 NO MOQ	品种齐全 In Full Range	

2. Outline dimension

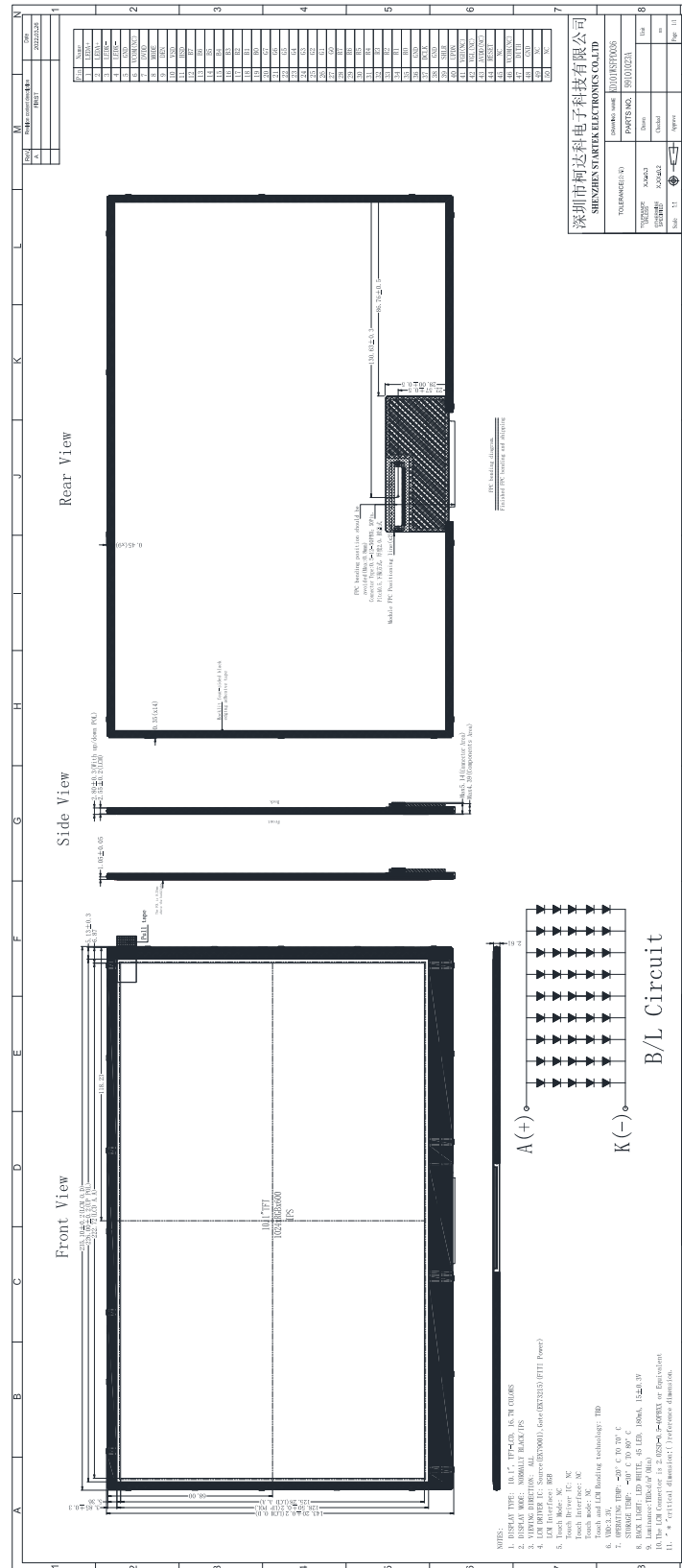

Part. No	KD101WSFPD036	REV	V1.1	Page 6 of 27
常备库存 Stock For Sale	长期供货 Long Time supply	支持小量 NO MOQ	品种齐全 In Full Range	

3. Input terminal Pin Assignment

NO.	SYMBOL	DISCRIPTION	I/O
1	LEDA+	LED Anode	P
2	LEDA+	LED Anode	P
3	LEDK-	LED Cathode	P
4	LEDK-	LED Cathode	P
5	GND	Ground	P
6	NC	--	--
7	DVDD	Power supply for digital circuits	P
8	MODE	DE / SYNC mode select under TTL mode. Normally pull high H : DE mode. L : HSD/VSD mode.	I
9	DEN	Data Input Enable. Active High to enable the data input bus under "DE Mode". Normally pull low.	I
10	VSD	Vertical Sync input for TTL mode. Negative polarity. (In LVDS Interface , connected to FPC and pull low)	I
11	HSD	Horizontal Sync input for TTL mode. Negative polarity.	IS
12-19	B7-B0	Blue data input	I
20-27	G7-G0	Green data input	I
28-35	R7-R0	Red data input	I
36	GND	Ground	P
37	DCLK	Input clock edge selection. Normally pull low	I
38	GND	Ground	P
39	SHLR	Horizontal shift direction (source output) selection(NOTE1)	I
40	UPDN	Vertical shift direction (gate output) selection(NOTE1)	I
41	NC	--	--
42	NC	--	--
43	NC	--	--

44	RESET	Global reset pin. Active low to enter reset state. Suggest to connecting with an RC reset circuit for stabilize Normally pull high. (R=10K, C=1uF)	I
45	NC	--	--
46	NC	--	--
47	DITH	Dithering function enable control. Normally pull low. DITHER="1", Enable internal dithering function. DITHER="0", Disable internal dithering function.	I
48	GND	Ground	P
49	NC	--	--
50	NC	--	--

Note1: When SHLR="0", set right to left scan direction.
 When SHLR="1", set left to right scan direction.
 When UPDN="0", set top to bottom scan direction.
 When UPDN="1", set bottom to top scan direction.

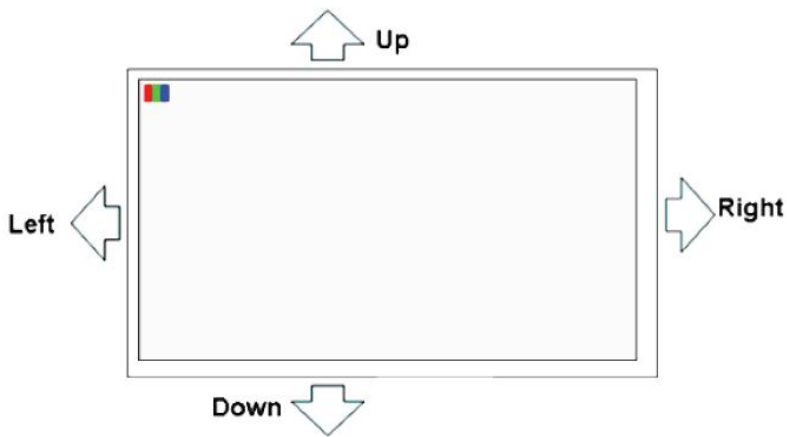

4. LCD Optical Characteristics

4.1 Optical specification

Item	Symbol	Condition	Min.	Typ.	Max.	Unit.	Note
Contrast Ratio	CR	$\Theta=0$	800	1000	--		(1)(2)
Response time	Rising	T_{R+T_F}	--	30	40	msec	(1)(3)
	Falling						
Color gamut	S(%)		41	46.5	--	%	
Color Filter Chromaticity	White	W_X	0.276	0.316	0.356		(1)(4) CA-310
		W_Y	0.297	0.337	0.377		
	Red	R_X	0.551	0.591	0.631		
		R_Y	0.308	0.348	0.388		
	Green	G_X	0.313	0.353	0.393		
		G_Y	0.521	0.561	0.601		
	Blue	B_X	0.119	0.159	0.199		
		B_Y	0.076	0.116	0.156		
Viewing angle	Hor.	Θ_L	--	85	--		(1)(4)
		Θ_R	--	85	--		
	Ver.	Θ_U	--	85	--		
		Θ_D	--	85	--		
Option View Direction	ALL						

*The data comes from the LCD specification.

Measuring Condition

Measuring surrounding : dark room

Ambient temperature : $25 \pm 2^\circ\text{C}$

15min. warm-up time.

Measuring Equipment

FPM520 of Westar Display technologies, INC., which utilized SR-3 for Chromaticity and BM-5A for other optical characteristics.

Part. No	KD101WSFPD036	REV	V1.1	Page 9 of 27
常备库存 Stock For Sale	长期供货 Long Time supply	支持小量 NO MOQ	品种齐全 In Full Range	

Note (1): Definition of Viewing Angle :

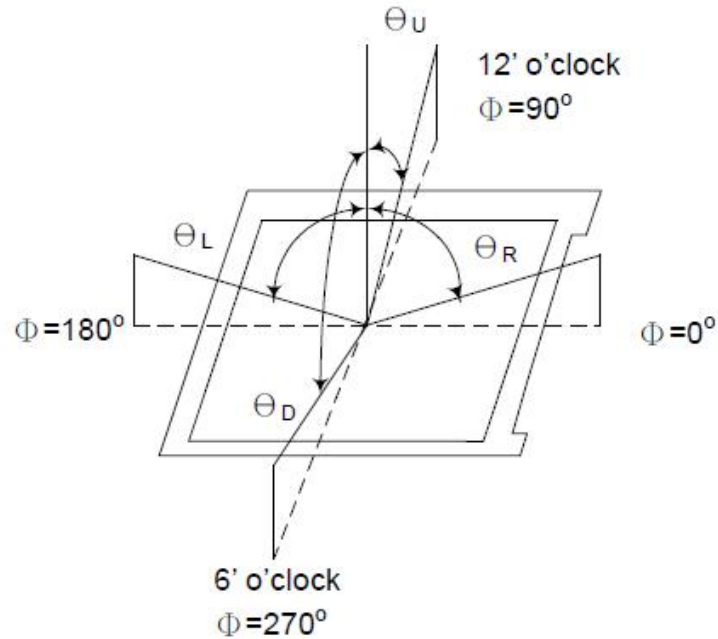

Note (2): Definition of Contrast Ratio(CR) :measured at the center point of panel

$$CR = \frac{\text{Luminance with all pixels white}}{\text{Luminance with all pixels black}}$$

Note (3): Response Time

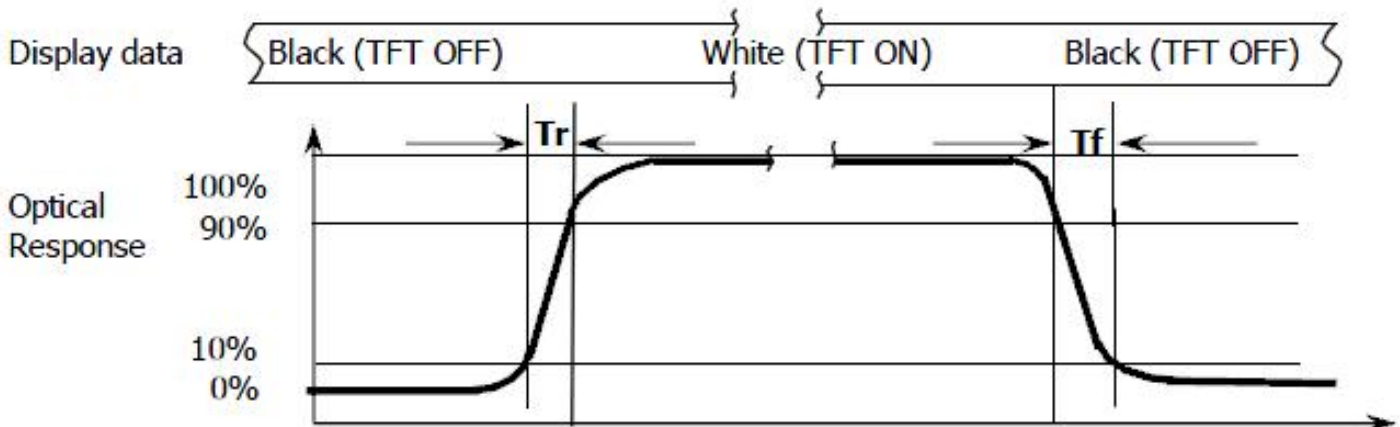

Part. No	KD101WSFPD036	REV	V1.1	Page 10 of 27
常备库存 Stock For Sale	长期供货 Long Time supply	支持小量 NO MOQ	品种齐全 In Full Range	

Note (4): Definition of optical measurement setup

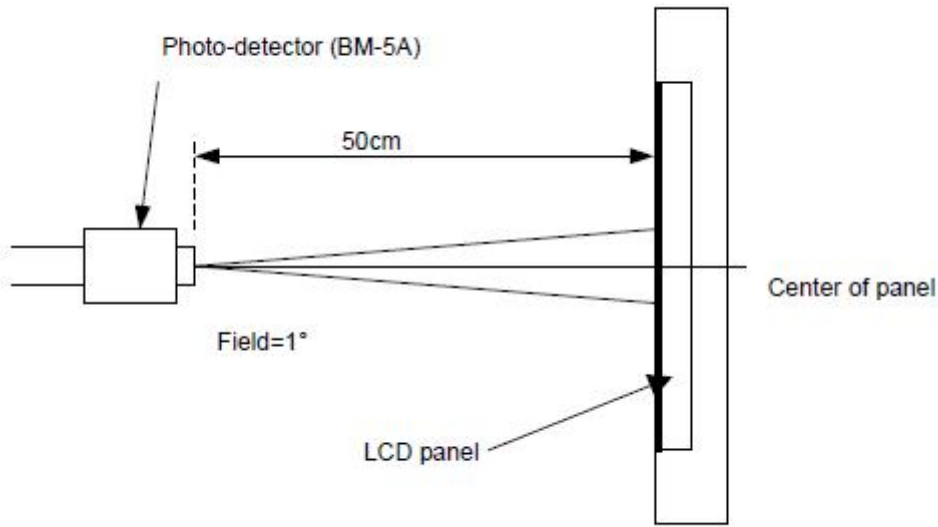

Part. No	KD101WSFPD036	REV	V1.1	Page 11 of 27
常备库存 Stock For Sale	长期供货 Long Time supply	支持小量 NO MOQ	品种齐全 In Full Range	

5. Electrical Characteristics

5.1 Absolute Maximum Rating

Characteristics	Symbol	Min.	Max.	Unit	Note
Digital Supply Voltage	DVDD	-0.5	3.6	V	Note1
Operating temperature	T _{OP}	-20	+70	°C	
Storage temperature	T _{ST}	-30	+80	°C	

NOTE1: If the absolute maximum rating of even is one of the above parameters is exceeded even momentarily, the quality of the product may be degraded. Absolute maximum ratings, therefore, specify the values exceeding which the product may be physically damaged. Be sure to use the product within the range of the absolute maximum ratings.

5.2 DC Electrical Characteristics

Characteristics	Symbol	Min.	Typ.	Max.	Unit	Note
Digital Supply Voltage	DVDD	3.0	3.3	3.6	V	
Normal mode Current consumption	IDD	--	110	220	mA	
Level input voltage	V _{IH}	0.7*DVDD	--	DVDD	V	
	V _{IL}	0	--	0.3*DVDD	V	
Level output voltage	V _{OH}	DVDD-0.4	--	--	V	
	V _{OL}	0	--	0.4	V	

5.3 LED Backlight Characteristics

The back-light system is edge-lighting type with 45 chips LED

Item	Symbol	Min.	Typ.	Max.	Unit	Note
Forward Current	I_F	--	180	--	mA	
Forward Voltage	V_F	--	15	--	V	
LCM Luminance	LV	500	550	--	cd/m ²	Note3
LED life time	Hr	50000	--	--	Hour	Note1,2
Uniformity	Avg	80	--	--	%	Note3

Note1: LED life time (Hr) can be defined as the time in which it continues to operate under the condition:

$T_a=25\pm3\text{ }^\circ\text{C}$, typical IL value indicated in the above table until the brightness becomes less than 50%.

Note 2: The “LED life time” is defined as the module brightness decrease to 50% original brightness at

$T_a=25\text{ }^\circ\text{C}$ and $I_L=180\text{mA}$. The LED lifetime could be decreased if operating I_L is larger than 180mA.

The constant current driving method is suggested.

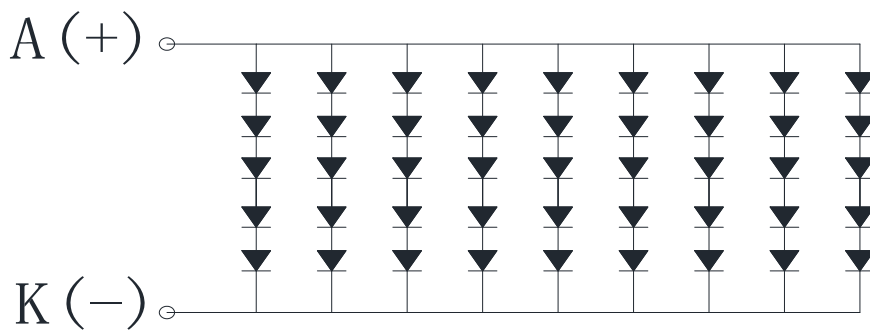

B/L Circuit

Note (3) Luminance Uniformity of these 9 points is defined as below:

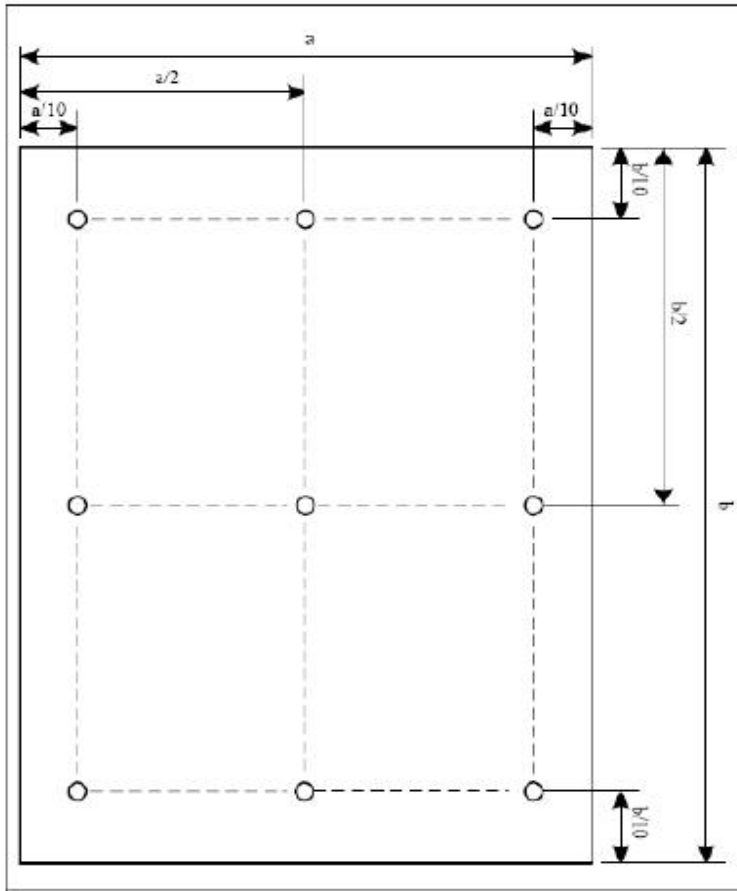

$$\text{Uniformity} = \frac{\text{minimum luminance in 9 points (1-9)}}{\text{maximum luminance in 9 points (1-9)}}$$

$$\text{Luminance} = \frac{\text{Total Luminance of 9 points}}{9}$$

Part. No	KD101WSFPD036	REV	V1.1	Page 14 of 27
常备库存 Stock For Sale	长期供货 Long Time supply	支持小量 NO MOQ	品种齐全 In Full Range	

6. AC Characteristic

6.1 Input Clock and Data Timing

Parameter	Symbol	Spec.			Unit	Condition
		Min.	Typ.	Max.		
DVDD Power On Slew Rate	TPOR	-	-	20	ms	From 0V to 90% DVDD
RSTB Pulse Width	TRst	50	-	-	us	DCLK=65MHz
DCLK Cycle Time	Tcph	14	-	-	ns	
DCLK Pulse Duty	Tcwh	40	50	60	%	
VSD Setup Time	Tvst	5	-	-	ns	
VSD Hold Time	Tvhd	5	-	-	ns	
HSD Setup Time	Thst	5	-	-	ns	
HSD Hold Time	Thhd	5	-	-	ns	
Data Setup Time	Tdsu	5	-	-	ns	D0[7:0],D1[7:0],D2[7:0] to DCLK
Data Hold Time	Tdhd	5	-	-	ns	D0[7:0],D1[7:0],D2[7:0] to DCLK
DEN Setup Time	Tesu	5	-	-	ns	
DEN Hold Time	Tehd	5	-	-	ns	

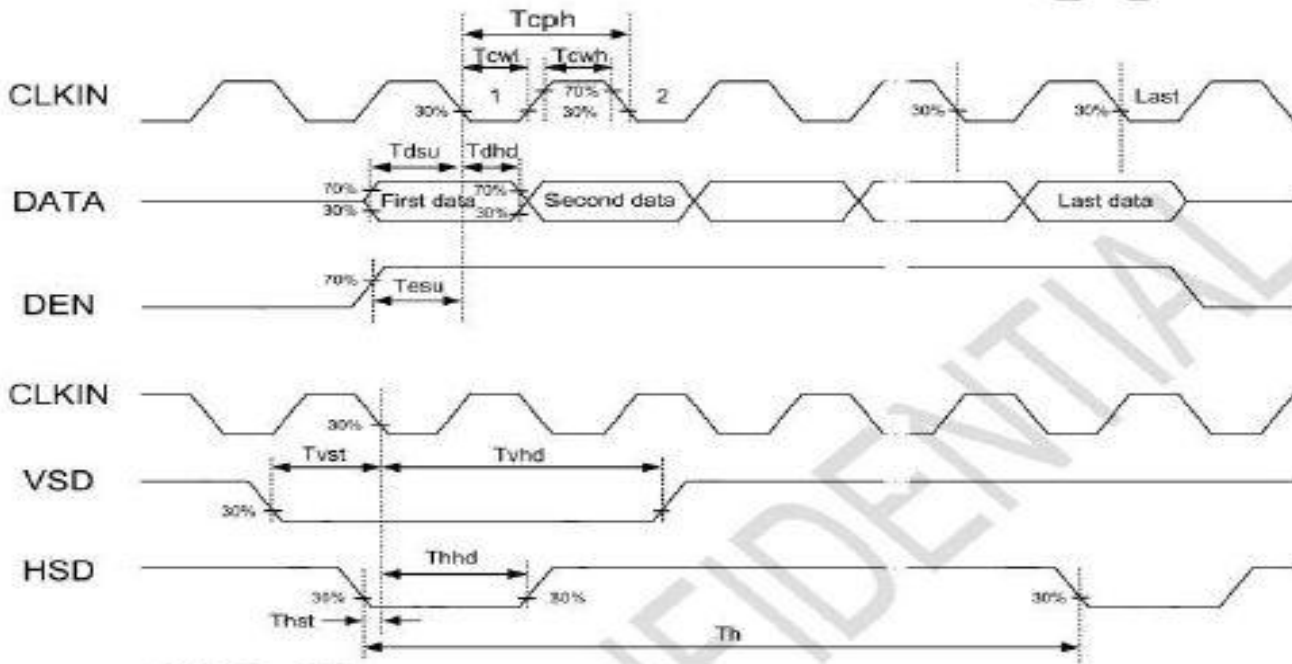

6.2 Input Timing

ITEM		SYMBOL	MIN.	TYP.	MAX.	UNIT	Note
DE MODE	Dot Clock	1/tCLK	45	51.2	57	MHz	
	DCLK Pulse Duty	Tcwh	40	50	60	%	
	Horizontal Total Time	tH	1324	1344	1364	tCLK	
	Horizontal Effective Time	tHA	1024			tCLK	
	Horizontal Blank Time	tHB	300	320	340	tCLK	
	Vertical Total Time	tV	625	635	645	tH	
	Vertical Effective Time	tVA	600			tH	
	Vertical Blank Time	tVB	25	35	45	tH	
SYNC MODE	Horizontal Total Time	TH	1324	1344	1364	tCLK	
	Horizontal Pulse Width	Thpw		20	-	tCLK	t _{hb} + t _{h_{pw}} = 160DCLK is fixed
	Horizontal Back Porch	Thb		140	-	tCLK	
	Horizontal Front Porch	Thfp	140	160	180	tCLK	
	Horizontal Effective Time	THA	1024			tCLK	
	Vertical Total Time	TV	625	635	645	tH	
	Vertical Pulse Width	Tvpw		3	-	th	t _{vpw} + t _{vb} = 23th is fixed
	Vertical Back Porch	Tvb	-	20	-	th	
	Vertical Front Porch	Tvfp	2	12	22	th	
Vertical Valid	Tvd	600			th		

6.3 DE Mode

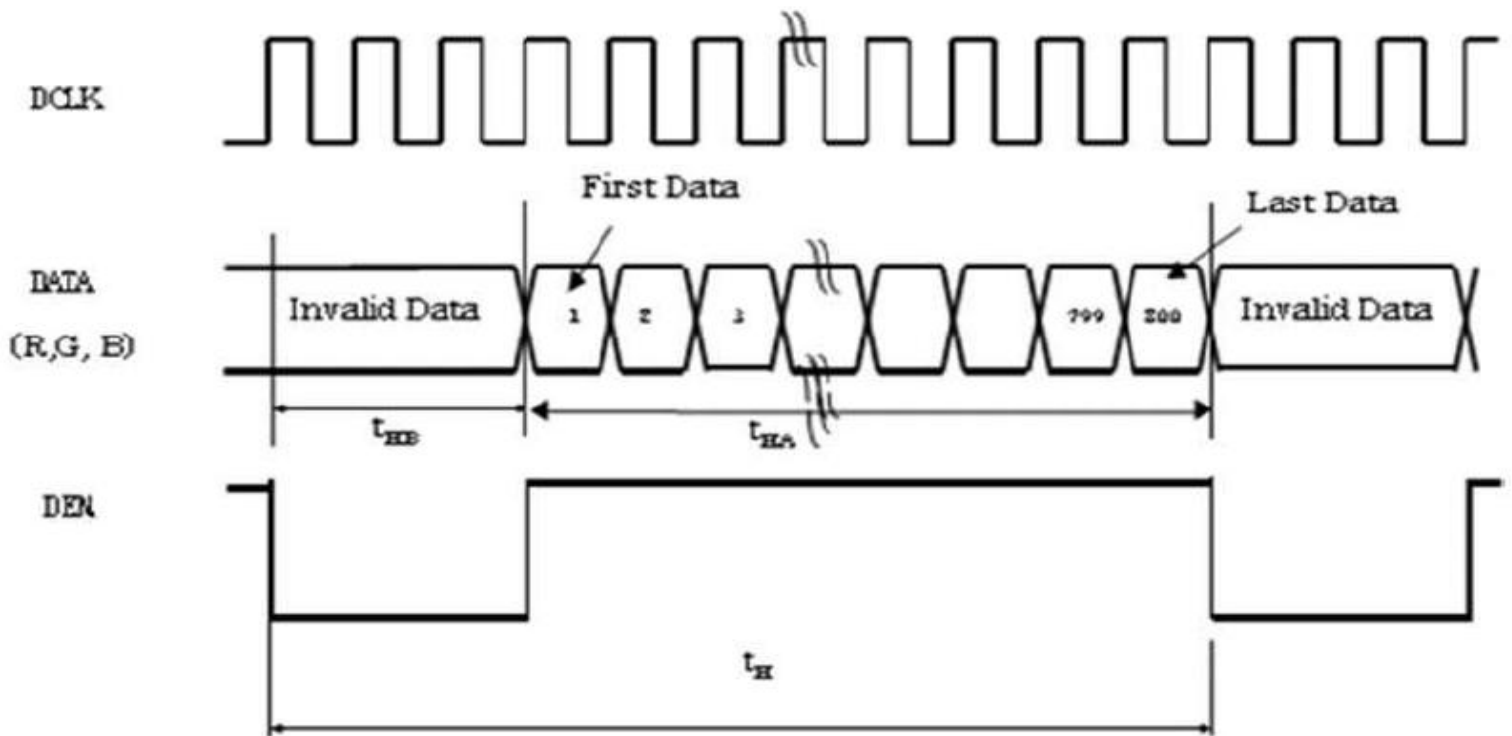

6.4 SYNC Mode

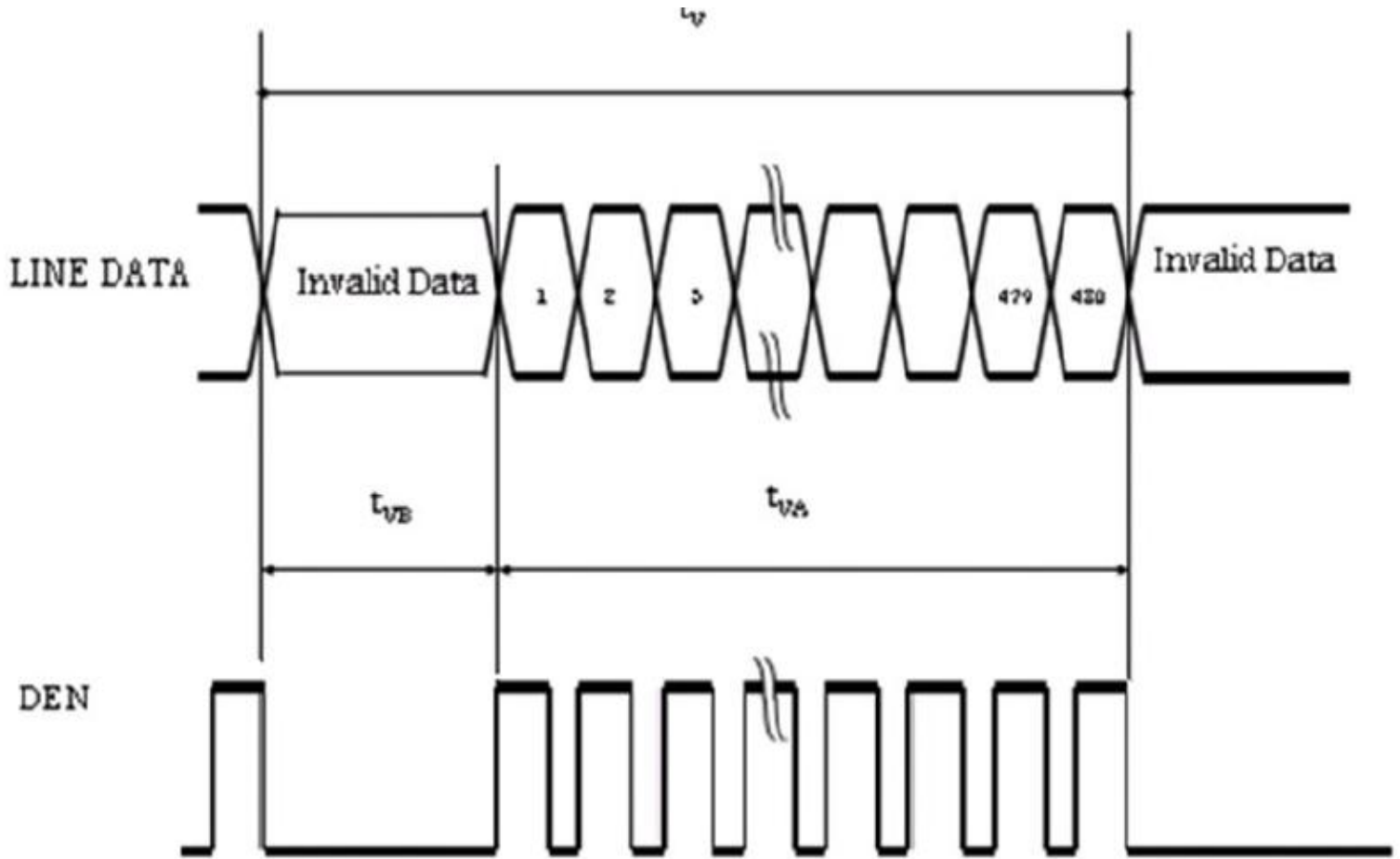

Part. No	KD101WSFPD036	REV	V1.1	Page 17 of 27
常备库存 Stock For Sale	长期供货 Long Time supply	支持小量 NO MOQ	品种齐全 In Full Range	

6.5 Data Input Format

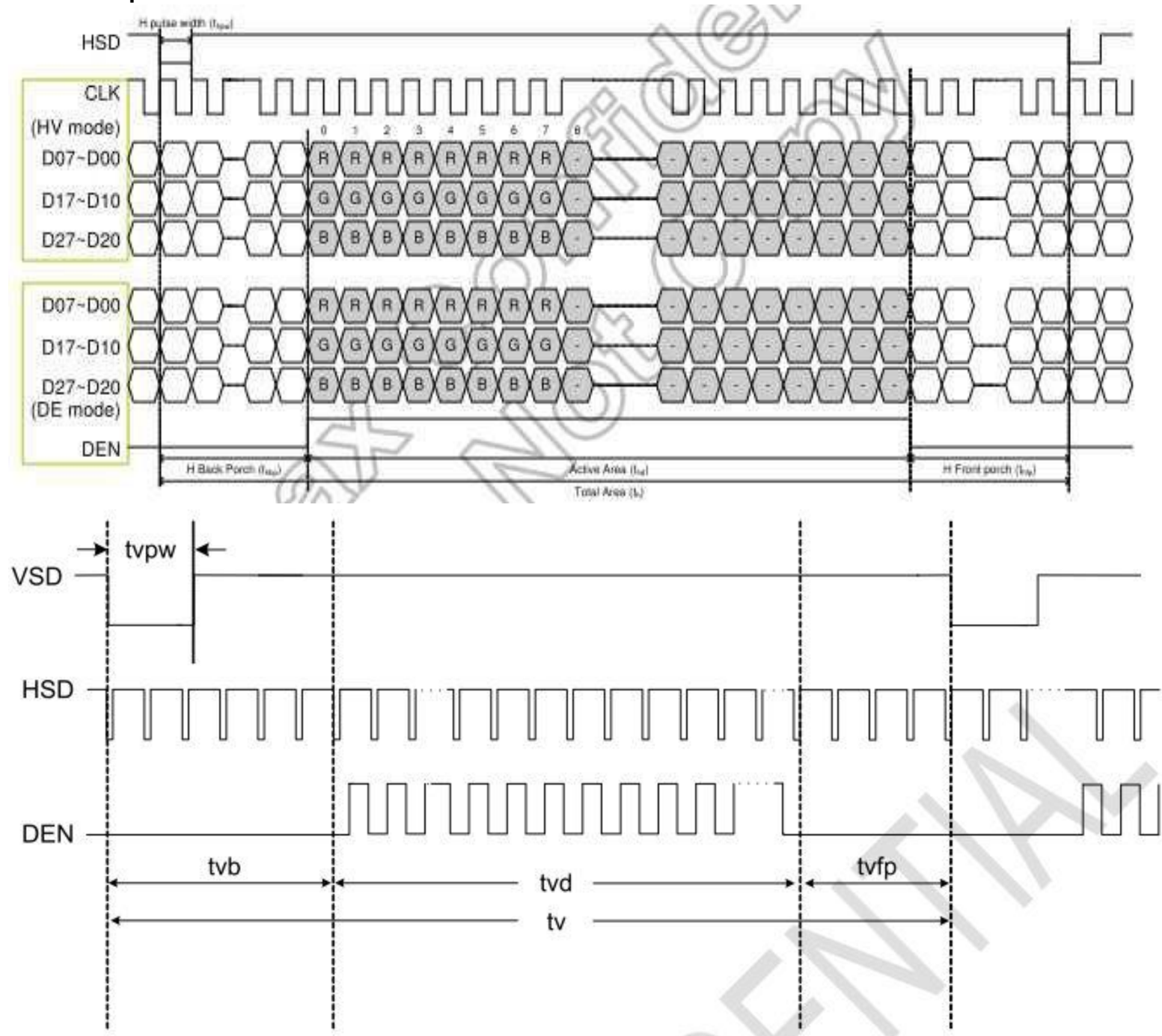

Part. No	KD101WSFPD036	REV	V1.1	Page 18 of 27
常备库存 Stock For Sale	长期供货 Long Time supply	支持小量 NO MOQ	品种齐全 In Full Range	

7. LCD Module Out-Going Quality Level

7.1 VISUAL & FUNCTION INSPECTION STANDARD

7.1.1 Inspection conditions

Inspection performed under the following conditions is recommended.

Temperature : $25\pm 5^{\circ}\text{C}$

Humidity : $65\%\pm 10\%\text{RH}$

Viewing Angle : Normal viewing Angle.

Illumination: Single fluorescent lamp (300 to 700Lux)

Viewing distance:30-50cm

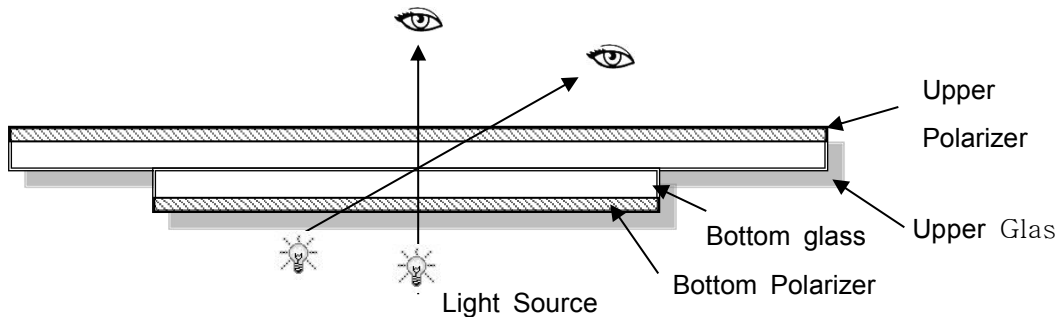

7.1.2 Definition

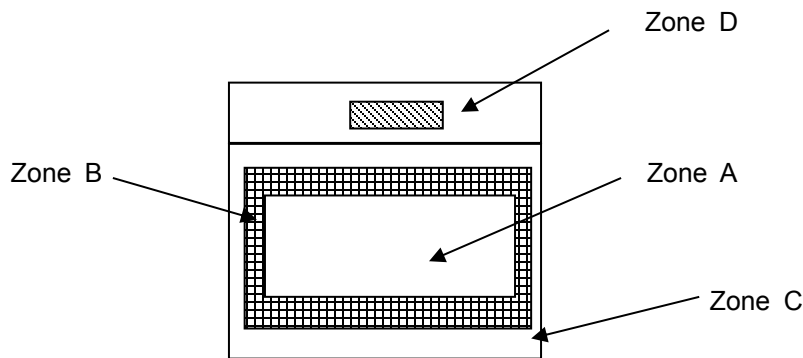

Zone A : Effective Viewing Area(Character or Digit can be seen)

Zone B : Viewing Area except Zone A

Zone C : Outside (Zone A+Zone B) which can not be seen after assembly by customer .)

Zone D : IC Bonding Area

Note:As a general rule ,visual defects in Zone C can be ignored when it doesn't effect product function or appearance after assembly by customer

Part. No	KD101WSFPD036	REV	V1.1	Page 19 of 27
常备库存 Stock For Sale	长期供货 Long Time supply	支持小量 NO MOQ	品种齐全 In Full Range	

7.1.3 Sampling Plan

According to GB/T 2828-2003 ; , normal inspection, Class II

AQL:

Major defect	Minor defect
0.65	1.5

LCD: Liquid Crystal Display , LCM: Liquid Crystal Module, CTP: Capacitive Touch Panel

No	Items to be inspected	Criteria	Classification of defects
1	Functional defects	1) No display, Open or miss line 2) Display abnormally, Short 3) Backlight no lighting, abnormal lighting. etc	Major
2	Missing	Missing components and etc	
3	Outline dimension	Overall outline dimension beyond the drawing is not allowed, deformation and etc	
4	Color tone	Color unevenness, refer to limited sample	Minor
5	Spot/Line defect	Light dot, Dim spot, (Note1) Polarizer Air Bubble, Polarizer accidented spot and etc	
6	Soldering appearance	Good soldering , Peeling off is not allowed and etc	
7	LCD/Polarizer/CTP	Black/White spot/line, scratch, crack, etc.	

Note1: a) Light dot: Dots appear bright and unchanged in size in which LCD panel is displaying under black pattern.



b) Dim dot: Dots appear dark and unchanged in size in which LCD panel is displaying under pure red, green, blue picture.

Part. No	KD101WSFPD036	REV	V1.1	Page 20 of 27
	常备库存 Stock For Sale	长期供货 Long Time supply	支持小量 NO MOQ	品种齐全 In Full Range

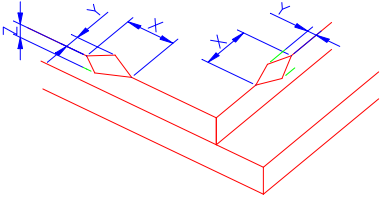
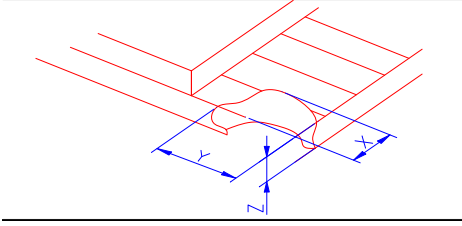
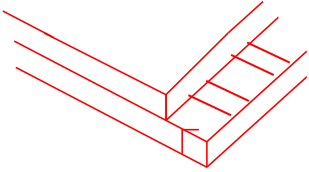
7.1.4 Criteria (Visual)

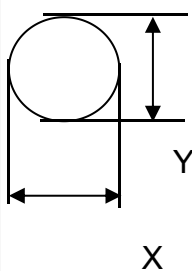
Number	Items	Criteria(mm)						
1.0 LCD Crack/Broken NOTE: X: Length Y: Width Z: Height L: Length of IT O, T: Height of LCD	(1) The edge of LCD broken	 <table border="1" data-bbox="756 667 1455 815"> <thead> <tr> <th>X</th> <th>Y</th> <th>Z</th> </tr> </thead> <tbody> <tr> <td>≤3.0mm</td> <td><Inner border line of the seal</td> <td>≤T</td> </tr> </tbody> </table>	X	Y	Z	≤3.0mm	<Inner border line of the seal	≤T
X	Y	Z						
≤3.0mm	<Inner border line of the seal	≤T						
	(2)LCD corner broken	 <table border="1" data-bbox="836 1124 1375 1223"> <thead> <tr> <th>X</th> <th>Y</th> <th>Z</th> </tr> </thead> <tbody> <tr> <td>≤3.0mm</td> <td>≤L</td> <td>≤T</td> </tr> </tbody> </table>	X	Y	Z	≤3.0mm	≤L	≤T
X	Y	Z						
≤3.0mm	≤L	≤T						
	(3) LCD crack	 <p style="text-align: center;">Crack Not allowed</p>						

2.0	Spot defect	① light dot (black/white spot , pinhole, stain, etc.)			
	 <p>$\Phi=(X+Y)/2$</p>	Zone	Acceptable Qty		
		Size (mm)	A	B	C
		$\Phi \leq 0.15$	Ignore		Ignore
$0.15 < \Phi \leq 0.25$		3(distance ≥ 10 mm)			
$0.25 < \Phi \leq 0.4$	2(distance ≥ 10 mm)				
	$\Phi > 0.4$	0			
		② Dim spot (light leakage, dent, dark spot, etc)			
		Zone	Acceptable Qty		
		Size (mm)	A	B	C
		$\Phi \leq 0.15$	Ignore		Ignore
		$0.15 < \Phi \leq 0.25$	3(distance ≥ 10 mm)		
		$0.25 < \Phi \leq 0.4$	2(distance ≥ 10 mm)		
		$\Phi > 0.4$	0		
		③ Polarizer accidented spot			
		Zone	Acceptable Qty		
		Size (mm)	A	B	C
		$\Phi \leq 0.2$	Ignore		Ignore
		$0.2 < \Phi \leq 0.5$	2(distance ≥ 10 mm)		
		$\Phi > 0.5$	0		
		④ Polarizer Bubble			
		Zone	Acceptable Qty		
		Size (mm)	A	B	C
		$\Phi \leq 0.2$	Ignore		Ignore
		$0.2 < \Phi \leq 0.4$	2(distance ≥ 10 mm)		
		$\Phi > 0.4$	0		

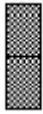
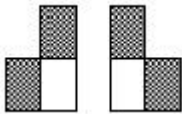
3.0	LCD Pixel defect	<p>Pixel bad points</p> <table border="1"> <thead> <tr> <th data-bbox="539 309 730 360">Item</th> <th data-bbox="730 309 1246 360">Zone A</th> <th data-bbox="1246 309 1497 360">Acceptable Qt</th> </tr> </thead> <tbody> <tr> <td data-bbox="539 360 730 521" rowspan="3">Bright dot</td> <td data-bbox="730 360 1246 416">Random</td> <td data-bbox="1246 360 1497 416">N≤2</td> </tr> <tr> <td data-bbox="730 416 1246 472">2 dots adjacent</td> <td data-bbox="1246 416 1497 472">N≤0</td> </tr> <tr> <td data-bbox="730 472 1246 521">3 dots adjacent</td> <td data-bbox="1246 472 1497 521">N≤0</td> </tr> <tr> <td data-bbox="539 521 730 689" rowspan="3">Dark dot</td> <td data-bbox="730 521 1246 577">Random</td> <td data-bbox="1246 521 1497 577">N≤3</td> </tr> <tr> <td data-bbox="730 577 1246 633">2 dots adjacent</td> <td data-bbox="1246 577 1497 633">N≤0</td> </tr> <tr> <td data-bbox="730 633 1246 689">3 dots adjacent</td> <td data-bbox="1246 633 1497 689">N≤0</td> </tr> <tr> <td data-bbox="539 689 730 1003">Distance</td> <td data-bbox="730 689 1246 1003"> 1. Minimum Distance Between Bright dots. 2. Minimum Distance Between dark dots 3. Minimum Distance Between dark and bright dot. </td> <td data-bbox="1246 689 1497 1003">5mm</td> </tr> <tr> <td colspan="2" data-bbox="539 1003 1246 1059">Total bright and dark dot</td> <td data-bbox="1246 1003 1497 1059">N≤4</td> </tr> </tbody> </table> <p>Note:</p> <p>A) Bright dot: Dots appear bright and unchanged in size in which LCD panel is displaying under black pattern.</p> <p>B) Dark dot: Dots appear dark and unchanged in size in which LCD panel is displaying under pure red, green, blue picture.</p> <p>C) 2 dot adjacent = 1 pair = 2 dots</p> <p>Picture:</p> <div style="display: flex; justify-content: space-around; align-items: flex-start;"> <div style="text-align: center;">  <p>2 dot adjacent</p> </div> <div style="text-align: center;">  <p>2 dot adjacent</p> </div> <div style="text-align: center;">  <p>2 dot adjacent (vertical)</p> </div> <div style="text-align: center;">  <p>2 dot adjacent (slant)</p> </div> </div>	Item	Zone A	Acceptable Qt	Bright dot	Random	N≤2	2 dots adjacent	N≤0	3 dots adjacent	N≤0	Dark dot	Random	N≤3	2 dots adjacent	N≤0	3 dots adjacent	N≤0	Distance	1. Minimum Distance Between Bright dots. 2. Minimum Distance Between dark dots 3. Minimum Distance Between dark and bright dot.	5mm	Total bright and dark dot		N≤4
Item	Zone A	Acceptable Qt																							
Bright dot	Random	N≤2																							
	2 dots adjacent	N≤0																							
	3 dots adjacent	N≤0																							
Dark dot	Random	N≤3																							
	2 dots adjacent	N≤0																							
	3 dots adjacent	N≤0																							
Distance	1. Minimum Distance Between Bright dots. 2. Minimum Distance Between dark dots 3. Minimum Distance Between dark and bright dot.	5mm																							
Total bright and dark dot		N≤4																							

4.0	Line defect (LCD /Polarizer backlight black/white line, scratch, stain)  W: width, L : length N : Count	<table border="1"> <thead> <tr> <th rowspan="2">Width(mm)</th> <th rowspan="2">Length(m)</th> <th colspan="3">Acceptable Qty</th> </tr> <tr> <th>A</th> <th>B</th> <th>C</th> </tr> </thead> <tbody> <tr> <td>$\Phi \leq 0.05$</td> <td>Ignore</td> <td colspan="2">Ignore</td> <td rowspan="3">Ignore</td> </tr> <tr> <td>$0.05 < W \leq 0.06$</td> <td>$L \leq 5.0$</td> <td colspan="2">$N \leq 3$</td> </tr> <tr> <td>$0.06 < W \leq 0.08$</td> <td>$L \leq 4.0$</td> <td colspan="2">$N \leq 2$</td> </tr> <tr> <td>$W > 0.08$</td> <td colspan="4">Define as spot defect</td> </tr> </tbody> </table>	Width(mm)	Length(m)	Acceptable Qty			A	B	C	$\Phi \leq 0.05$	Ignore	Ignore		Ignore	$0.05 < W \leq 0.06$	$L \leq 5.0$	$N \leq 3$		$0.06 < W \leq 0.08$	$L \leq 4.0$	$N \leq 2$		$W > 0.08$	Define as spot defect			
		Width(mm)			Length(m)	Acceptable Qty																						
			A	B		C																						
		$\Phi \leq 0.05$	Ignore	Ignore		Ignore																						
		$0.05 < W \leq 0.06$	$L \leq 5.0$	$N \leq 3$																								
$0.06 < W \leq 0.08$	$L \leq 4.0$	$N \leq 2$																										
$W > 0.08$	Define as spot defect																											
5.0	Electronic Components SMT.	Not allow missing parts, solderless connection, cold solder joint, mismatch, The positive and negative polarity opposite																										
6.0	Display color & Brightness.	1. Color: Measuring the color coordinates, The measurement standard according to the datasheet or samples. 2. Brightness: Measuring the brightness of White screen, The measurement standard according to the datasheet or Samples.																										
7.0	LCD Mura/Waving/ Hot spot	Not visible through 5% ND filter in 50% gray or judge by limit sample if necessary.																										

Criteria (functional items)

Number	Items	Criteria (mm)
1	No display	Not allowed
2	Missing segment	Not allowed
3	Short	Not allowed
4	Backlight no lighting	Not allowed
5	CTP no function	Not allowed

8. Reliability Test Result

Item	Condition	Inspection after test
High Temperature Operating	70℃,96H	Inspection after 2~4hours storage at room temperature, the sample shall be free from defects: 1.Air bubble in the LCD; 2.Non-display; 3.Missing segments/line; 4.Glass crack; 5.Current IDD is twice higher than initial value.
Low Temperature Operating	-20℃, 96HR	
High Temperature Storage	80℃, 96HR	
Low Temperature Storage	-30℃, 96HR	
High Temperature & High Operating	+60℃, 90% RH ,96 hours.	
Thermal Shock (Non-operation)	-10℃,30 min ↔60℃,30 min, Change time:5min 20CYC.	
ESD test	C=150pF, R=330,5points/panel Air:±8KV, 5times; Contact:±6KV, 5 times; (Environment: 15℃~35℃, 30%~60%).	
Vibration (Non-operation)	Frequency range:10~55Hz, Stroke:1.5mm Sweep:10Hz~55Hz~10Hz 2 hours for each direction of X.Y.Z. (6 hours for total) (Package condition).	
Box Drop Test	1 Corner 3 Edges 6 faces,80cm(MEDIUM BOX)	

Remark:

- The test samples should be applied to only one test item.
- Sample size for each test item is 5~10pcs.
- For Damp Proof Test, Pure water(Resistance > 10MΩ) should be used.
- In case of malfunction defect caused by ESD damage, if it would be recovered to normal state after resetting, it would be judged as a good part.
- Failure Judgment Criterion: Basic Specification, Electrical Characteristic, Mechanical Characteristic, Optical Characteristic.
- The color fading mura of polarizing filter should not care.

Part. No	KD101WSFPD036	REV	V1.1	Page 25 of 27
常备库存 Stock For Sale	长期供货 Long Time supply	支持小量 NO MOQ	品种齐全 In Full Range	

9. Cautions and Handling Precautions

9.1 Handling and Operating the Module

(1) When the module is assembled, it should be attached to the system firmly.

Do not warp or twist the module during assembly work.

(2) Protect the module from physical shock or any force. In addition to damage, this may cause improper operation or damage to the module and back-light unit.

(3) Note that polarizer is very fragile and could be easily damaged. Do not press or scratch the surface.

(4) Do not allow drops of water or chemicals to remain on the display surface.

If you have the droplets for a long time, staining and discoloration may occur.

(5) If the surface of the polarizer is dirty, clean it using some absorbent cotton or soft cloth.

(6) The desirable cleaners are water, IPA (Isopropyl Alcohol) or Hexane.

Do not use ketene type materials (ex. Acetone), Ethyl alcohol, Toluene, Ethyl acid or Methyl chloride. It might permanent damage to the polarizer due to chemical reaction.

(7) If the liquid crystal material leaks from the panel, it should be kept away from the eyes or mouth. In case of contact with hands, legs, or clothes, it must be washed away thoroughly with soap.

(8) Protect the module from static; it may cause damage to the CMOS ICs.

(9) Use finger-stalls with soft gloves in order to keep display clean during the incoming inspection and assembly process.

(10) Do not disassemble the module.

(11) Protection film for polarizer on the module shall be slowly peeled off just before use so that the electrostatic charge can be minimized.

(12) Pins of I/F connector shall not be touched directly with bare hands.

(13) Do not connect, disconnect the module in the "Power ON" condition.

(14) Power supply should always be turned on/off by the item 6.1 Power On Sequence & 6.2 Power Off Sequence

9.2 Storage and Transportation.

(1) Do not leave the panel in high temperature, and high humidity for a long time.

It is highly recommended to store the module with temperature from 0 to 35 °C and relative humidity of less than 70%

(2) Do not store the TFT-LCD module in direct sunlight.

(3) The module shall be stored in a dark place. When storing the modules for a long time, be sure to adopt effective measures for protecting the modules from strong ultraviolet radiation, sunlight, or fluorescent light.

(4) It is recommended that the modules should be stored under a condition where no condensation is allowed. Formation of dewdrops may cause an abnormal operation or a failure of the module.

In particular, the greatest possible care should be taken to prevent any module from being operated where condensation has occurred inside.

(5) This panel has its circuitry FPC on the bottom side and should be handled carefully in order not to be stressed.

Part. No	KD101WSFPD036	REV	V1.1	Page 26 of 27
	常备库存 Stock For Sale	长期供货 Long Time supply	支持小量 NO MOQ	品种齐全 In Full Range

10. Packing

---TBD-----

Part. No	KD101WSFPD036	REV	V1.1	Page 27 of 27
	常备库存 Stock For Sale	长期供货 Long Time supply	支持少量 NO MOQ	品种齐全 In Full Range